

# Craze initiation in poly(methyl methacrylate) exposed to n-alkanes

M. KAWAGOE

*Department of Mechanical Engineering, Toyama National College of Technology, Hongo 13, Toyama 939, Japan*

M. KITAGAWA

*Department of Mechanical Engineering, Faculty of Technology, Kanazawa University, Kodatsuno 2-40-20, Kanazawa 920, Japan*

The critical stresses for craze initiation were measured on poly(methyl methacrylate) exposed to n-alkanes both under static torsion and under static tension at room temperature. Crazes are observed even under torsion where the dilatational stress is absent, as the authors previously pointed out. The critical stresses for craze initiation under both types of loading increase with increasing liquid molar volume, and decrease with increasing loading time. The ratio of the critical crazing stress under torsion to that under tension is almost constant irrespective of the kind of liquid and the loading time. In contrast with the critical crazing strain measured by the use of the elliptical bending device, the critical crazing stresses do not show a lower limiting value even under long-time (200 min) loading, and are correlated with neither the solubility parameter nor the equilibrium solubility of the liquid predicted from the solution theory.

## 1. Introduction

The phenomenon of crazing has been interpreted as a dilatational plastic deformation in glassy polymers. This interpretation is based on two experimental observations that (1) a craze consists of microvoids and elongated fibrils [1] and (2) craze nucleation does not occur in air under pure shear where the dilatational stress is absent [2]. However, in the specimen in contact with some organic liquids, crazes can initiate and grow not only under pure shear but also in biaxial stress field where the hydrostatic component is compressive [3-6]. No reasonable explanation has been so far provided for this great difference in crazing behaviour. In order to establish a criterion for crazing, this problem is required to be solved. For that, it is necessary to elucidate what is the fundamental role of the environment in craze nucleation.

The effect of the environmental liquid on crazing has been extensively studied. Kambour and co-workers [7-11] measured the critical crazing strain  $\epsilon_c$  of many polymer solids exposed to a wide variety of liquid environments. According to them,  $\epsilon_c$  decreases as the difference between the solubility parameters of the liquid and the polymer becomes small. Jacques and Wyzgoski [12] revealed that  $\epsilon_c$  in polycarbonate decreases with increasing the equilibrium solubility of normal and branched alkanes predicted from the solution theory. Iisaka *et al.* [13, 14] investigated the crazing kinetics of polystyrene in n-alcohols, and indicated that  $\epsilon_c$  shows the time dependence attributed to the diffusion of liquid into the polymer and there exists a lower limiting value in  $\epsilon_c$  which can be correlated to the equilibrium solubility.

The results mentioned above were obtained by the

use of the elliptical bending jig devised by Bergen [15]. The measurements of  $\epsilon_c$  with this device seem to not avoid the stress relaxation in the liquid with great diffusivity into the polymer, as Kramer pointed out [16]. Therefore it is unclear whether the lower limiting value in  $\epsilon_c$  is intrinsic to crazing or due to the stress relaxation. In addition, although the  $\epsilon_c$  data of Kambour *et al.* obtained in various liquid environments were very useful practically, it is fairly difficult to find the primary determinant in environmental crazing because of too wide a variation in fundamental factors of the liquid such as molecular weight (volume), viscosity, surface tension, and polarity etc.

Several investigators [17-19] have considered the effect of the applied stress on the equilibrium solubility in relation to craze initiation. According to them, the tensile or the dilatational stress increases the equilibrium solubility, which leads to a decrease in the resistance to crazing. The comparison of the results under torsion and tension seems to be adequate to confirm this hypothesis, but so far this has not been done.

Thus it is necessary to examine the crazing behaviour both under torsion and under tension with reference to the loading time and a few basic properties of the liquid. In the experiments described below, the critical stresses for craze initiation in poly(methyl methacrylate) (PMMA) exposed to n-alkanes have been determined under static torsion as well as static tension. The results are compared with the experimental results and the explanations mentioned above.

## 2. Experimental procedure

The material used was commercially available PMMA

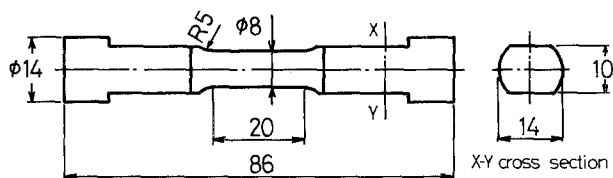

Figure 1 Specimen for torsion and tension tests. Dimensions are in mm.

rod, 15 mm in diameter (Mitsubishi Rayon Co., Japan). Solid cylindrical specimens were machined from the rods to the dimensions shown in Fig. 1, and were polished circumferentially with a fine buffing compound ( $0.05 \mu\text{m}$  alumina). They then were annealed at  $90^\circ\text{C}$  for 2 h to remove residual stresses due to machining and slowly cooled to room temperature in a forced-air oven.

The testing machine constructed for the experiment, which is the same type as that devised by Sternstein and Myers [2], is shown Fig. 2. Tensile and torsional loads were applied by means of a dead weight through a lever and a pulley, respectively.

The experiments were performed in n-alkanes listed in Table I [20, 21]. These liquids have in common a linear structure, no polarity, and perfect wettability with PMMA because of their surface tension which is less than the critical one of PMMA  $39 \text{ mN}^{-1} \text{ m}$  at  $20^\circ\text{C}$  [22]. As soon as the specimen was immersed in the liquid vessel, a predetermined load was applied. After the applied load was held constant during either period of 2, 20, or 200 min, the specimen was unloaded and removed from the apparatus to examine the initiation of crazes through an optical microscope at a magnification of  $\times 100$ . If a craze had formed during the test period, a new specimen was prepared and subjected to a lower stress. The critical stress required for craze nucleation can be determined by repeating this procedure. The temperature of the test liquid was measured with a chromel–alumel (CA) thermocouple positioned in close vicinity to the specimen, and was  $20 \pm 1^\circ\text{C}$  during the test. To maintain a constant temperature of the liquid, the testing machine was placed in a thermostatically controlled room.

### 3. Results and discussion

The crazing data obtained under torsion for 20 min are plotted against the liquid molar volume  $V_l$  in Fig. 3, where the open and the solid circles denote the stress levels of crazing and no-crazing, respectively. The critical stress for crazing can be determined from these data as the middle point between the open and the solid marks. The critical stresses determined in this

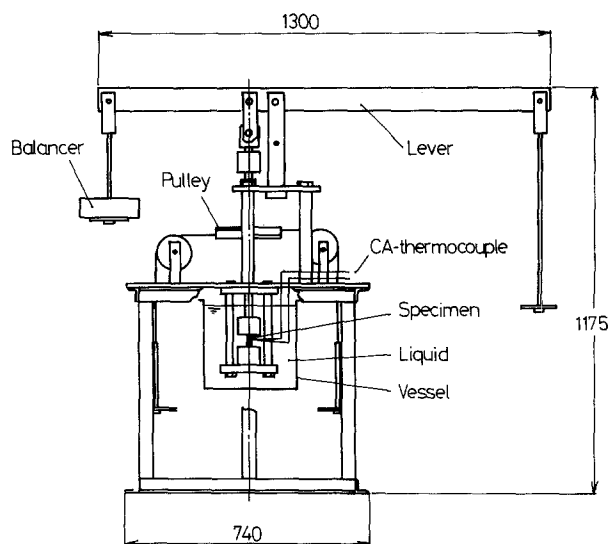

Figure 2 Schematic illustration of apparatus to provide static torsion and tension.

way are plotted as a function of  $V_l$  for all the loading times in Fig. 4. Quite similar results are obtained when the term  $V_l$  is replaced by the liquid viscosity  $\eta$ , since an increase in  $V_l$  is equivalent to an increase in  $\eta$  as shown in Table I. It should be noted that crazes initiate even under torsion and the crazing stresses under both types of loading increase in  $V_l$  for any loading times. This trend supports the work of Narisawa [23] on polystyrene and polycarbonate under constant rate tension in several alcohols and hydrocarbons.

The ratios of the crazing stress under torsion to that under tension are plotted against the logarithmic loading time for all the test liquids in Fig. 5. The value of the ratio is found to be almost independent of both the kind of liquid and the loading time, and is about 1.5. Gent [18] and Okamoto and Ohde [19] suggested that the dilatational stress facilitates the absorption of the environmental liquid in the solid polymer and as a consequence lowers the crazing resistance. It is unclear, however, whether their hypothesis is verified by the present result that the higher stress is required for crazing under torsion than under tension, because a number of scratches lying circumferentially on the specimen surface seem to affect the crazing behaviour. According to a recent experiment of the authors [24], the critical tensile stress for crazing is clearly influenced by the direction of the surface scratch to the tensile axis. Thus, for the trend shown in Fig. 5, it should be noted that the value of the ratio is almost constant irrespective of the kind of liquid and the

TABLE I Physical constants and solubilities for n-alkanes used

Liquid	Molecular weight	Molar volume $V_l$ ( $\text{cm}^3 \text{ mol}^{-1}$ )	Viscosity ( $20^\circ\text{C}$ ) (mPa sec)	Surface tension ( $20^\circ\text{C}$ ) ( $\text{mN m}^{-1}$ )	Solubility parameter $\delta_1$ ( $\text{MJ m}^{-3}$ ) <sup>1/2</sup>	Predicted equilibrium solubility	
						19.4	20.5
n-Pentane	72.15	116.2	0.23	15.5	14.4	0.132	0.064
n-Hexane	86.18	131.6	0.31	18.0	14.9	0.150	0.070
n-Nonane	128.26	178.6	0.72	23.0	15.6	0.158	0.065
n-Dodecane	170.34	228.6	1.50	25.4	16.2	0.182	0.066

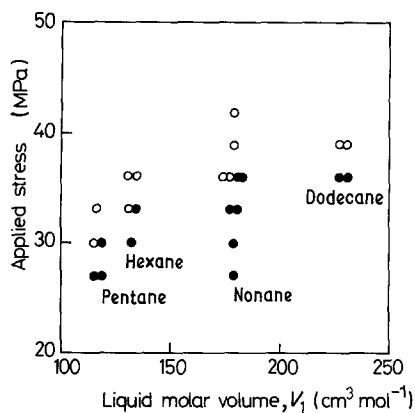

Figure 3 Craze data under torsion for 20 min plotted against liquid molar volume. (○) Craze, (●) no craze.

loading time, because it implies the existence of a criterion for crazing applicable independently of these factors.

The variation of the crazing stress with the loading time is shown in Fig. 6; the crazing stress is lowered as the loading time increases. Iisaka *et al.* [13, 14] measured the critical crazing strain  $\epsilon_c$  of polystyrene in n-alcohols using the elliptical bending device, and revealed that  $\epsilon_c$  is also lowered with increasing loading time and then attains a lower limiting value after 10 min loading. According to them, the time dependence of  $\epsilon_c$  is attributed to the diffusion of the liquid into the polymer and the lower limiting value in  $\epsilon_c$  can be correlated to the equilibrium degree of swelling. The diffusion coefficient will increase as the liquid molar volume or the liquid viscosity decreases [13, 14, 25]. The small molecules of the liquid diffusing into the polymer will increase the mobility of the macro-

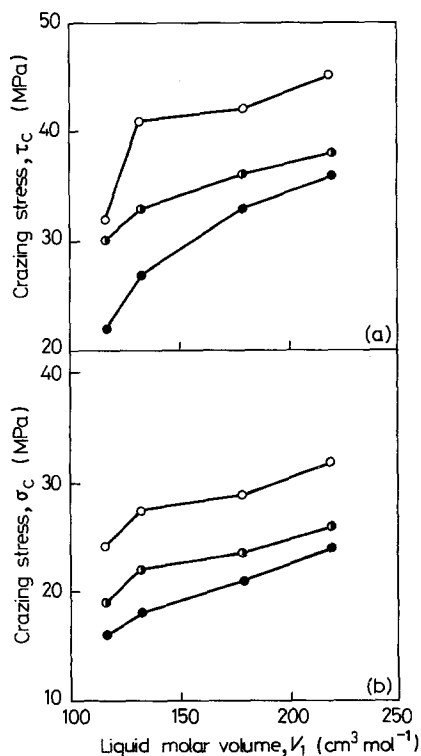

Figure 4 Critical stress for crazing versus liquid molar volume under (a) torsion and (b) tension.  $\tau_c$  and  $\sigma_c$  mean critical crazing stresses under torsion and tension, respectively. (○) 2 min, (●) 20 min, (●) 200 min.

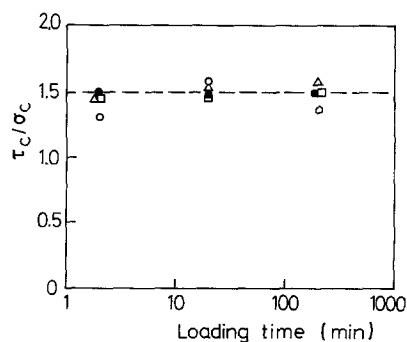

Figure 5 Ratio of crazing stress under torsion to that under tension plotted against logarithmic loading time. (○) Pentane, (●) hexane, (△) nonane, (□) dodecane.

molecular chains and as a consequence may lead to a decrease in the crazing resistance. In the crazing stress data presented in the figure, the rate of stress reduction seems in general to gradually decrease with time, but the lower limiting value is hard to find at least for the loading time of a few ten minutes. Thus it may be interpreted that the time-dependent crazing stress is governed by the diffusion coefficient rather than the equilibrium solubility of the environmental liquid in the polymer.

The solution theory [26, 27] shows that the equilibrium solubility increases with a decrease in the difference between the solubility parameters (SP) of the polymer and the liquid. Kambour *et al.* [7–11] investigated the relation between  $\epsilon_c$  and the SP values on a wide variety of combinations of polymer and liquid, and revealed that  $\epsilon_c$  decreases as the SP value of the test liquid approaches that of the polymer. The relationship between the crazing stress and the SP value obtained in the present experiment is shown in Fig. 7, where the extent of the SP value of PMMA is

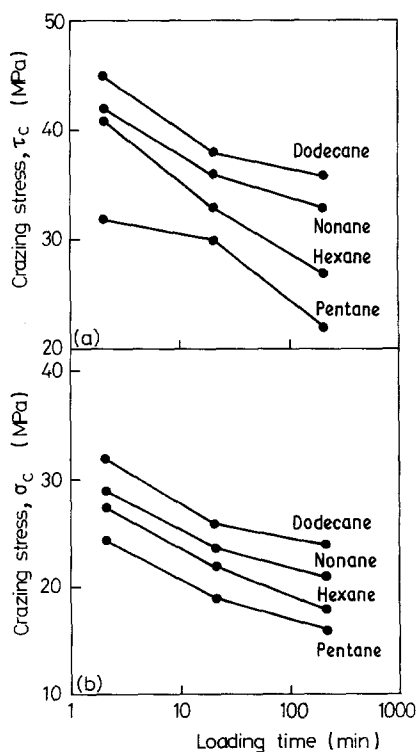

Figure 6 Time dependence of crazing strain under (a) torsion and (b) tension.

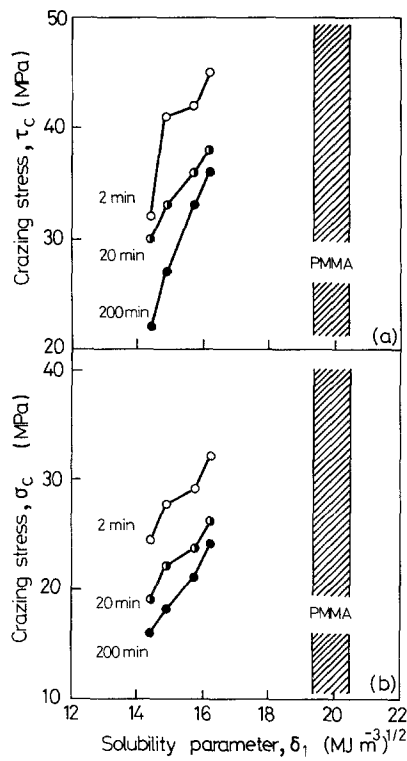

Figure 7 Relation of crazing stress to solubility parameter of liquid in (a) torsion and (b) tension. (○) 2 min, (●) 20 min, (●) 200 min.

represented by the hatched lines. It is evident that both the results under torsion and tension have in common a trend opposite to the expectation of Kambour *et al.*

According to the result of Jacques and Wyzgoski [12] on polycarbonate in normal and branched alkanes a linear relation is obtained between  $\epsilon_c$  and the equilibrium solubility predicted from the following equation based on the solution theory [26, 27].

$$\ln \phi_1 + \left(1 - \frac{V_1}{V_2}\right)(1 - \phi_1) + \chi_s(1 - \phi_1)^2 + \frac{V_1(\delta_1 - \delta_2)^2}{RT}(1 - \phi_1)^2 = 0 \quad (1)$$

where  $\phi_1$  is the volume fraction of the liquid,  $V_1$  and  $V_2$  are the molar volume of the liquid and the polymer, respectively,  $\chi_s$  is the entropy contribution to an interaction parameter between the polymer and the liquid,  $\delta_1$  and  $\delta_2$  are the solubility parameters of the liquid and the polymer, respectively,  $R$  is the gas constant, and  $T$  is the absolute temperature. Using the values listed in Table I and  $\chi_s = 0.34$ , we can obtain the equilibrium solubilities of the test liquids in PMMA. The calculated results are also presented in Table I for  $\delta_2$  of PMMA 19.4 and 20.5 ( $\text{MJ m}^{-3}$ )<sup>1/2</sup> in consideration of the extent of  $\delta_2$  value. Fig. 8 shows the relation of the critical crazing stress under long-time (200 min) loading to the predicted equilibrium solubilities. For both the values of  $\delta_2$ , a reasonable explanation can not be provided.

As is evident from the above, the critical crazing stress measured under constant stress condition can be correlated with neither the solubility parameter nor the predicted equilibrium solubility. It will probably be governed by the diffusion coefficient of the liquid in the polymer. But at the present time this prediction

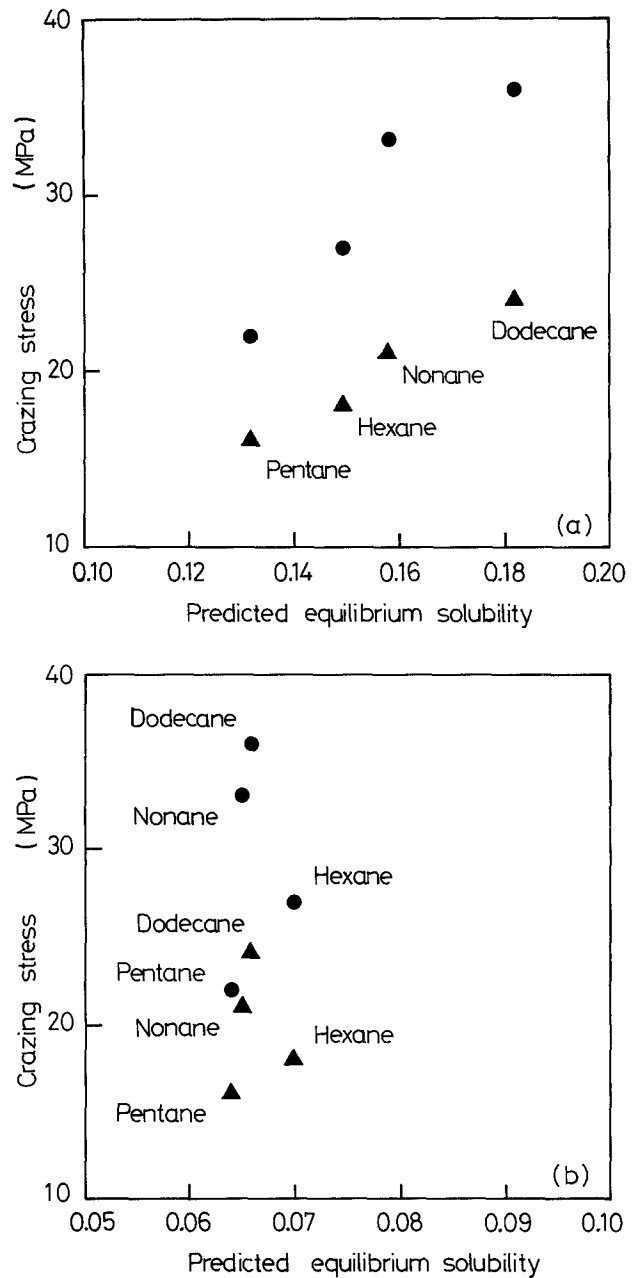

Figure 8 Relation of crazing stress for 200 min loading to the equilibrium solubility calculated from Equation 1 with (a)  $\delta_2 = 19.4$  ( $\text{MJ m}^{-3}$ )<sup>1/2</sup> and (b)  $\delta_2 = 20.5$  ( $\text{MJ m}^{-3}$ )<sup>1/2</sup>. (●) Torsion, (▲) tension.

seems difficult to confirm because of lack of our knowledge on the diffusion problem in a solid polymer-liquid system under the action of stress.

#### 4. Conclusion

The critical stresses for crazing of PMMA immersed in n-alkanes were investigated both under static torsion and under static tension at room temperature.

As has been shown in the previous studies, crazes are found to initiate even under torsion where the dilatational stress is absent. Both the crazing stresses under torsion and tension increase with increasing molar volume of the environmental liquid, and decrease with increasing loading time. The ratio of the the crazing stress under torsion to that under tension is almost constantly independent of the type of n-alkanes and the loading time. This implies that there exists a criterion for crazing applicable independently

of these factors. In the combination of PMMA and n-alkane, the relationship between the crazing stress and the SP is incompatible with the expectation of Kambour *et al.* that the crazing stress decreases as the difference between the SP values of the liquid and the polymer becomes small. In addition, the crazing stress cannot be correlated with the equilibrium solubility predicted from the solution theory in contrast with the experimental trend of the crazing strain observed by Jacques and Wyzgoski. Thus it may be concluded that the time-dependent crazing stress is governed by the diffusion coefficient rather than the SP value and the equilibrium of the environmental liquid in the polymer.

### Acknowledgement

The authors wish to thank Professor Y. Hori, University of Tokyo, for valuable discussions.

### References

1. O. K. SPURR, Jr. and W. D. NIEGISCHE, *J. Appl. Polym. Sci.* **6** (1962) 585.
2. S. S. STERNSTEIN and F. A. MYERS, *J. Macromol. Sci., Phys.* **B8** (1973) 539.
3. M. KITAGAWA, *J. Polym. Sci., Polym. Phys. Ed.* **14** (1976) 2095.
4. R. A. DUCKETT, B. C. GOSWAMI, L. S. A. SMITH, I. M. WARD, and A. M. ZIHLIF, *Brit. Polym. J.* **10** (1978) 11.
5. M. MATSUSHIGE, S. V. RADCLIFFE, and E. BAER, *J. Mater. Sci.* **10** (1975) 833.
6. M. KAWAGOE and M. KITAGAWA, *J. Polym. Sci., Polym. Phys. Ed.* **19** (1981) 1423.
7. R. P. KAMBOUR, *J. Polym. Sci., Macromol. Rev.* **7** (1973) 1.
8. G. A. BERNIER and R. P. KAMBOUR, *Macromolecules* **1** (1968) 393.
9. R. P. KAMBOUR, E. E. ROMAGOSA, and C. L. GLUNER, *Macromolecules* **5** (1972) 335.
10. R. P. KAMBOUR, C. L. GRUNER, and E. E. ROMAGOSA, *J. Polym. Sci., Polym. Phys. Ed.* **11** (1973) 1879.
11. *Idem*, *Macromolecules* **7** (1974) 249.
12. C. H. M. JACQUES and M. G. WYZGOSKI, *J. Appl. Polym. Sci.* **23** (1979) 1153.
13. K. HISAKA, Y. NISHIMOTO, and K. SHIBAYAMA, *J. Polym. Sci., Polym. Phys. Ed.* **17** (1979) 791.
14. K. HISAKA and K. SHIBAYAMA, *J. Appl. Polym. Sci.* **24** (1979) 2113.
15. R. L. BERGEN Jr, *Soc. Petroleum Eng. J.* **18** (1962) 283.
16. E. J. KRAMER, in "Developments in Polymer Fracture", edited by E. H. Andrews (Applied Science, London, 1979) p. 95.
17. H. B. BROWN, *Polymer* **19** (1978) 1186.
18. A. N. GENT, *J. Mater. Sci.* **5** (1970) 925.
19. H. OKAMOTO and Y. OHDE, *Polymer* **23** (1982) 1204.
20. T. ASAHARA, N. TOKURA, M. OOKAWARA, J. KUMANOTANI, and M. SENOO, in "Youzai Handbook" (Kodansha, Tokyo, 1976) (in Japanese).
21. H. BURRELL, in "Polymer Handbook", edited by J. Brandrup and H. Immergut (Interscience, New York, 1966) IV-p. 337.
22. E. G. SHAFRIN, *ibid.* III-p. 221.
23. I. NARISAWA, *J. Polym. Sci., A2*, **10** (1972) 1789.
24. M. KAWAGOE and M. KITAGAWA, unpublished data (TNCT, 1985).
25. E. SOUTHERN and A. G. THOMAS, *Trans. Faraday Soc.* **63** (1967) 1913.
26. P. J. FLORY, *J. Chem. Phys.* **9** (1941) 660.
27. M. L. HUGGINS, *ibid.* **9** (1941) 440.

Received 13 October 1986  
and accepted 22 January 1987